

SECTION A-A

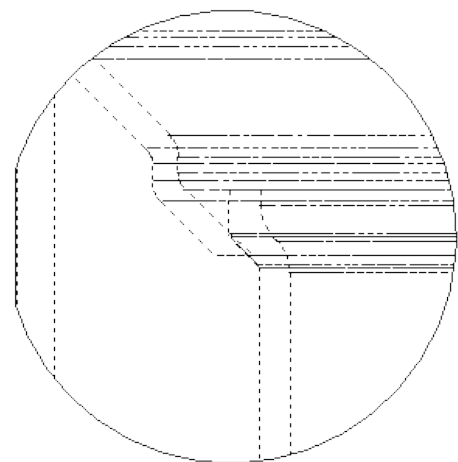

DETAIL A
SCALE 1 : 1

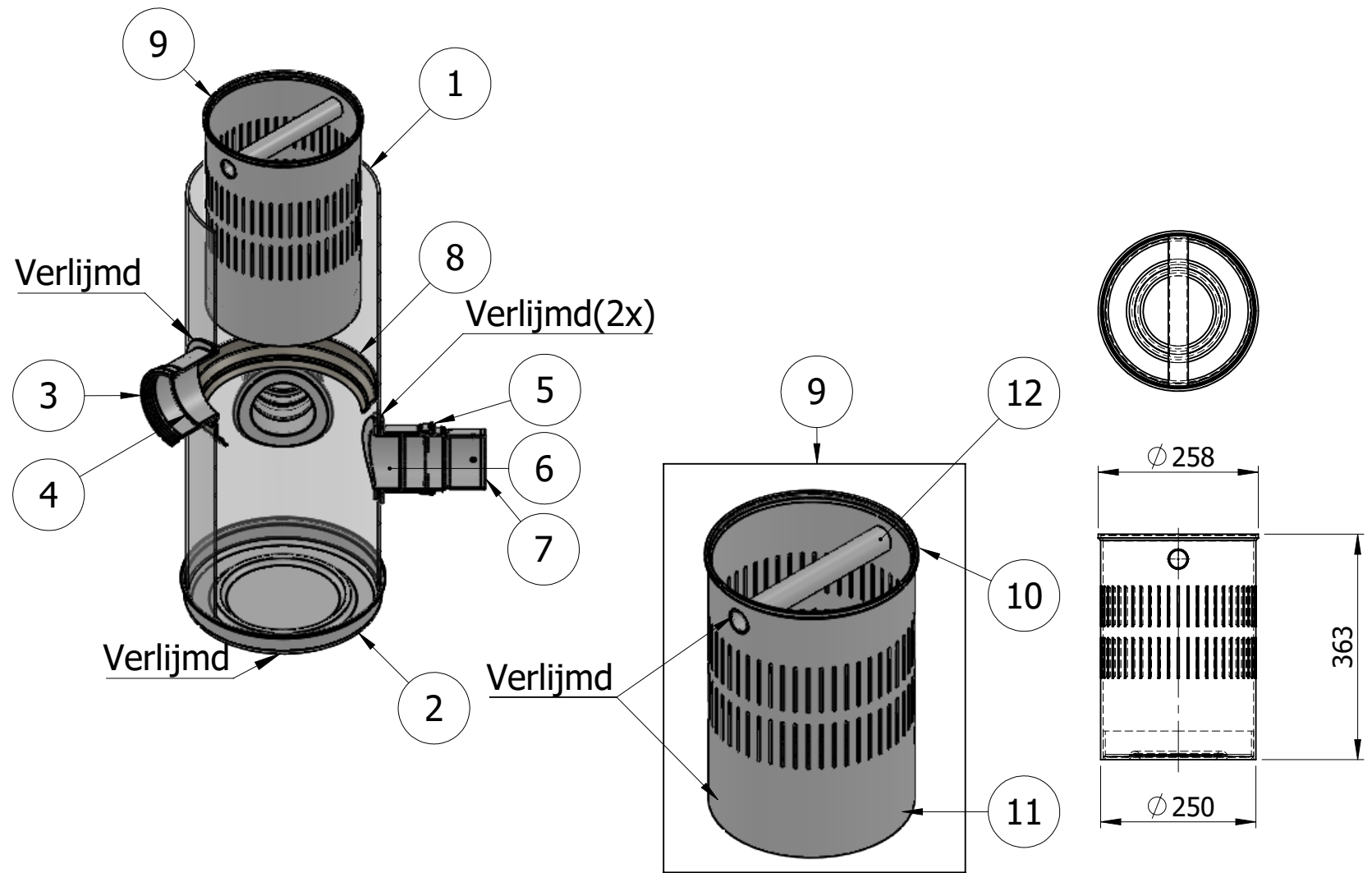

Pos.	QTY.	Description~Configuration	PartNo/Note	Size / Length Angle Angle	Material	Weight
12	1	Handgreep			PVC-U	68.09 g
11	1	Inwendig Deksel OD250 SDR65	41000230000		PVC-U	412.24 g
10	1	Geperforeerde Buis OD250 SDR51	40500300000		PVC-U	1443.80 g
9	1	Assy Vuilcollector met Filter	80500300000		PVC-U	1924.13 g
8	1	Rozet OD305~00 Default	41000670000		PVC-U	249.79 g
7	2	Drainage Verloopstuk DIA110-100	80400400000		PVC-U	177.14 g
6	2	Putinlaat Binnenstuk OD315 ID110	Dyka 20025299		PVC-U	131.96 g
5	2	Putinlaat OD315 ID110	Dyka 20025299		PVC-U	280.37 g
4	1	Putinlaat Binnenstuk OD315 ID125	Dyka 20025314		PVC-U	134.00 g
3	1	Putinlaat OD315 ID125	Dyka 20025302		PVC-U	319.27 g
2	1	Afsluitkap Slagvast ID315	81005630000		PVC-U	0.37 g
1	1	Buis OD315 SDR65			PVC-U	5171.10 g

Material	Various	PartNo/Note	-
Size		Customer	Hydrorock Schiedam
Color	-	Reference	Zandvangput 315-3x125 met Filter
Finish	-	Modification	-
Weight	9348.81 g	Drawn	CN
Standard	-	Date	11-09-2018
Scale	1:10 Sheet 1 of 1	Checked	-
Dimensions in Millimeters, Tolerances unless otherwise specified:		Checked	-
Angles in Degrees / Tolerance ±2°		A3 Do NOT Scale	
From:	0 30 100 300 1000	Assy Zandvangput 315-1x125-2x110-45+Drainageverloop 110-100	
To:	30 100 300 1000 -	8050031000000	
Tolerance:	±2 ±3 ±4 ±5 ±10	NYLOPLAST EUROPE B.V. www.nyloplast.nl P.O. BOX 5113 3295 ZG 'S-GRAVENDEEL THE NETHERLANDS TELEPHONE: +31-78-6732044 TELEFAX: +31-78-6734489	

© Nyloplast. All drawings, plans, designs, models, calculations, texts, photographs, and illustrations in this document are copyright protected works of Nyloplast. These works also contain confidential information and know-how exclusively owned by Nyloplast. It is not permissible to copy or use this document or any part of its contents, or to disclose or make available the same to third parties, or to make any communications concerning the same, without the written consent of Nyloplast. While preparing the present document, Nyloplast has taken the utmost care to ensure the accuracy and completeness of the information contained therein. However, Nyloplast can in no case be held liable for any damage resulting from any inaccuracy or incompleteness of the information contained in the present document. All studies and calculations made by Nyloplast, and the information contained in the present document are required to be submitted for approval to the executive architect or engineer in the case of projects for which the intervention of an architect and/or engineer is mandatory under the law.